

Congrout® 1000

HIGH PERFORMANCE NON SHRINK PRECISION GROUT

DESCRIPTION

Congrout 1000 is a fine precision non shrink, high performance grout with extended working time. **Congrout 1000** complies to ASTM C1107, Type C.

USES & ADVANTAGES

Congrout 1000 uses for the installation of anchor bolts, heavy machinery base-plates, column sole plates, bridge bearings and all areas requiring precision grouting.

Advantages include:-

- Repair work and cavity filling.
- Flowable and self levelling.
- Able to fill intricate voids.
- Ready to use.
- High strength.
- Good dimensional stability.
- No bleeding or segregation.
- Good expansion.
- Compensates for shrinkage in both plastic and hardened state.

PROPERTIES

Appearance: Grey powder
Bulk Density: Approx. 1.56-1.60 kg/litre
Yield: Approx. 74-78 x 25 kg/bags/m³ of grout depending on water content

Bond Strength to Concrete: > 2.5 N/mm² at 28 days
 ASTM D 4541 (Concrete failure)

Drying Shrinkage: < 500 micro strain
 23oC C/RH 50% at 28 days

ASTM C490
Resistivity: < 12,000 ohm cm at 28 days

Expansion of up to 1% or greater in unset material according to ASTM C827.

Drying shrinkage is compensated for complying with the requirements of ASTM 1107.

Initial Set - 2.3-3.4 hours

Final Set - 4-5.6 hours

APPROXIMATE FLOW DISTANCES AT 23°C

Grout Water cement	Gap Depth mm.	Approx. Flow distance in cm.	
		Head Height 10 cm.	Head Height 25 cm.
15% by weight of grout	10	40 cm.	140 cm.
	20	100 cm.	270 cm.
	30	160 cm.	>310 cm.
	40	240 cm.	>310 cm.
16% by weight of grout	10	100 cm.	270 cm.
	20	200 cm.	>310 cm.
	30	>300 cm.	>310 cm.
	40	>300 cm.	>310 cm.

Flow distance will be effected by surface conditions, temperature, height of head and mixing time.

SURFACE PREPARATION

Surfaces should be clean, sound and free from oil, grease, laitance and loose particles. Metal surfaces should also be clean & free from rust, oil & grease.

MIXING

Congrout 1000 should be mixed using a suitable mixer. For flowable consistency use a slow speed <400 R.P.M. hand drill and paddle. For large works use a high shear vane grout mixer. Drum mixers may not mix sufficiently.

Powder should be added to the pregauged clean water. For J rote of 8-10 seconds approx. 15-16% of water by weight of **Congrout 1000** should be used. Do not add more than the maximum water content. Mix for up to 5 minutes.

APPLICATION

Ensure the substrate is correctly prepared. No contamination and saturated with water at least 3 - 4 hours prior to pouring the grout. No free water should be left. During application ensure air entrained into the grout is able to escape through relief holes. Maintain continuous head when base-plate grouting. Mortar flow should not be interrupted. Formwork should not allow grout loss.

Ensure there is no water standing in bolt holes. If possible grout anchor bolts first then the mortar bed in a second operation. The distance between anchor bolt and substrate should be at least 3 x max. diameter of mortar aggregates approx. 10 mm. A cable or chain may be used to make sure that all cavities are filled.

IMPORTANT NOTES

Use **Congrout 1000** with minimum gaps of 5 mm. and maximum depths of 125-150 mm. Temperature will affect setting time and strength gain. Normal curing practice should be maintained.

CURING

To prevent rapid surface drying and crazing, use a suitable curing compound from Cormix's Corcure range **Corcure 90**.

CLEANING

Clean all tools with water immediately after use.

PACKAGING

4 Ply. 25 kg. plastic lined bags.

STORAGE & SHELF LIFE

Store in dry shaded conditions. The shelf life is at least 12 months if kept dry in original packaging. High temperatures and humidity may reduce shelf life.

HEALTH & SAFETY

Congrout 1000 is alkaline avoid contact with skin & eyes. Gloves, goggles and dust mask should be worn. Remove from skin with soapy water. Splashes in the eyes should be washed out with copious amounts of clean water and medical attention sought.

Congrout 1000 is non-flammable.

Congrout® 1000

HIGH PERFORMANCE NON SHRINK PRECISION GROUT

TYPICAL CHARACTERISTICS AT 30°C UNDER LABORATORY CONDITIONS

Water Content (%)	Consistency (J rote)	Setting time@25°C (minutes) ASTM C-191-01a/ ASTM C807		Bleeding ASTM C940 ASTM C232	Average Compressive Strengths (N/mm ²) - ASTM C-109			
		Initial	Final		1 day	3 days	7 days	28 days
15-16	8-12 seconds	170-200	200-230	0	40-55	50-65	60-75	70-80
15.5	10 seconds	> 175	> 205	0	> 42	> 52	> 62	> 70

Typical drawing for baseplate installation

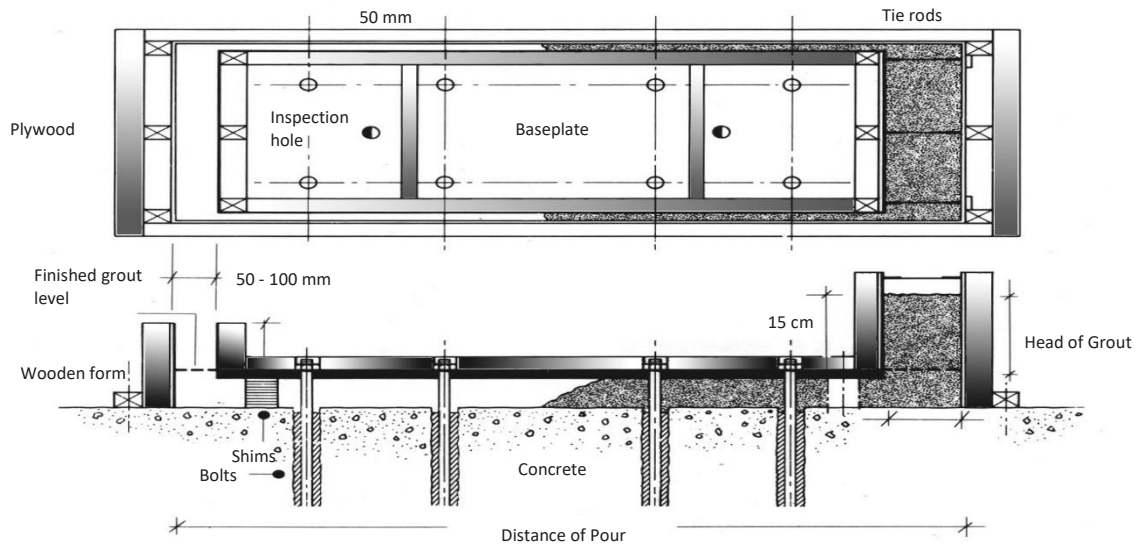

Typical hopper details

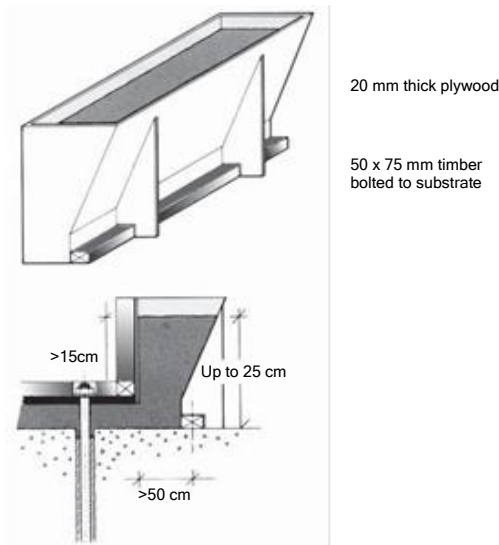

TECHNICAL SERVICE

The Cormix International Technical Service Department is available to assist you in the correct use of our products and its resources are at your disposal entirely without obligation.

QUALITY ASSURANCE

ISO 9001 : 2015 verified by TUV Nord

CONTACT DETAILS

Cormix International Limited
 89 Romkloa Rd., Sansab, Minburi, Bangkok 10510
 Tel. (66 2) 917 3955-8, 543 8890
 Fax. (66 2) 917 3959, 543 8891
<http://www.cormix.com>

NOTE: Every reasonable precaution is taken in the manufacture of all CORMIX-products to ensure that they comply with CORMIX's high standard of quality. The recommendations and properties of the product are based upon what is believed to be the most reliable information available and are not intended as recommendations which infringe on other patents. Although all CORMIX-products are subject to rigid quality tests, no specific guarantee can be given, because results depend, not only on quality, but also on other factors beyond our control. We welcome therefore consultation in the event of doubt concerning application, or performance, and point out those oral recommendations, which vary from the instructions contained herein, are not binding without written confirmation by CORMIX. All transactions shall be subject to our terms and conditions of sale-delivery-and-service. This data sheet supersedes the previous one and a reprint may be issued without notice to supersede this edition, as and when deemed necessary. The information given in this leaflet is to the best of our knowledge true and reliable. Field service where provided does not constitute supervisory responsibility. Our guarantee is therefore limited to the quality of materials delivered.