

# Congrout® 4000

## NON SHRINK HIGH EARLY STRENGTH PRECISION GROUT

### DESCRIPTION

A cementitious non shrink precision grout with high early & final strengths specifically for applications where early loading is required. A self leveling, premixed, non metallic grout which produces a dense durable homogeneous mix with no long term shrinkage. **Congrout 4000** complies to ASTM C1107, Type C.

### USES & ADVANTAGES

Developed to provide a flowable grout for precision grouting where high early strength is a necessity e.g. bridge bearings, machinery base-plates, column sole plates, anchor & rail bolts etc.

#### Advantages include the following:-

- High flow characteristics to fill voids easily.
- No bleeding and controlled expansion.
- Excellent durability. Free calcium oxide compensates shrinkage in both plastic and hardened stages.
- Silica fume improves strengths & long term durability.
- Expansive component shows excellent high heat & seawater resisting characteristics.
- Non rusting, contains no chlorides, non toxic, non corrosive.
- Ready to use & economical.
- Excellent dimensional stability.
- Early strength allows early loading.
- Good resistance to air & waterborne corrosive elements.
- Chloride Free.

### PROPERTIES

<b>Appearance:</b>	Grey powder
<b>Bulk Density:</b>	Approx. 1.60-1.62 kg./litre
<b>Yield:</b>	Approx. 74-75 x 25 kg/bags/m <sup>3</sup> of grout depends on water content
<b>Slump Cone:</b>	≥90 cm
<b>Bond Strength to Concrete:</b>	> 2.5 N/mm <sup>2</sup> at 28 days (Concrete failure)
ASTM D 4541	
<b>Drying Shrinkage:</b>	< 500 micro strain
23°C C/RH 50%	at 28 days
ASTM C490	
<b>Resistivity:</b>	< 12,000 ohm cm at 28 days

### SURFACE PREPARATION

Surface should be clean, sound and free from oil, grease, laitance and loose particles. Metal surfaces should also be clean & free from rust, oil & grease. Bolt holes or fixing pockets must be cleaned out with blown clean air.

### MIXING

**Congrout 4000** should be mixed using a suitable mixer. For flowable consistency use a hand drill and paddle with a speed of < 400 rpm. For large works use a high shear vane grout mixer. Drum mixers may not mix effectively.

Powder should be added to the pregauged water. A free flowing and self leveling grout can be obtained at a mix ratio of 25 kg. powder to 3.375 - 3.750 litres of water.

### APPLICATION

Ensure the substrate is correctly prepared, no contamination and saturated with water at least 3 - 4 hours prior to pouring the grout. No free water should be left. Ensure air entrained into the grout is able to escape. Maintain continuous head when base-plate grouting. Mortar flow should not be interrupted. Formwork should not allow grout loss. Base plates must be clean and free from oil, grease or scale. Air venting holes should be provided to allow venting in isolated spots. Place the grout within 10 minutes of mixing.

### CURING

To prevent rapid surface drying and crazing, use a suitable curing compound from Cormix's Corcure range. e.g. **Corcure 90**. At temperatures below 20°C early strength gain maybe affected.

### IMPORTANT NOTES

- Cure the grout.
- Do not add other materials to the grout.
- Do not re-temper after initial set.
- Bolt holes should be grouted prior to grouting between substrate and base plate.
- Continuous flow should be maintained with a continuous head of grout.
- Large volumes may be pumped. At temperatures above 35°C - 40°C cooling of water with ice will make handling & placement easier. Mixers & tools should be kept shaded.

### CONSUMPTION

Depending on water content used approximately 74-75 x 25 kg bags for 1 m<sup>3</sup> of mortar.

### CLEANING

Clean all tools with water immediately after use.

## Congrout® 4000

NON SHRINK HIGH EARLY STRENGTH PRECISION GROUT

### TYPICAL PERFORMANCE CRITERIA

Water Content (%)	Consistency (J rote) Initial	Bleeding ASTM C940 / ASTM C232	Wet State Expansion	Setting time @25°C (minutes) ASTM C191-01a / ASTM C807		Average Compressive Strengths (N/mm <sup>2</sup> ) ASTM C109			
				Initial	Final	8 hours	10 hours	24 hours	28 days
13.5	18-22 sec	0	1-2 %	65	75	>42	>56	>70	>90
14.0	11-15 sec	0	1-2 %	75	90	>40	>53	>67	>85
14.5	8-12 sec	0	1-2 %	85	105	>30	>45	>60	>80

**Note :** These are typical results mixing time, water content and ambient temperature will effect result.

#### Typical hopper set up For grouting with Congrout 4000

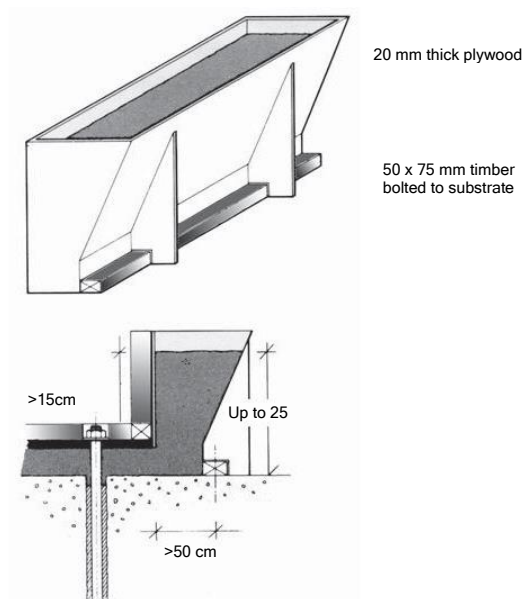

### PACKAGING

4 Ply. 25 kg. plastic lined bags.

### STORAGE & SHELF LIFE

Store in dry shaded conditions. The shelf life is at least 9 months if kept dry in original packaging. High temperatures and humidity may reduce shelf life.

### HEALTH & SAFETY

During use avoid inhalation of dust & contact with skin & eyes. Wear protective clothing. In case of contact with skin, rinse with plenty of clean water, then cleanse with soap and water. In case of contact with eyes, rinse immediately with plenty of clean water and seek medical advice. If swallowed, seek medical attention immediately  
- DO NOT induce vomiting.

### TECHNICAL SERVICE

The Cormix International Technical Service Department is available to assist you in the correct use of our products and its resources are at your disposal entirely without obligation.

### QUALITY ASSURANCE

ISO 9001 : 2008 verified by TUV Nord

### CONTACT DETAILS

#### Cormix International Limited

Regional Office,

89 Romklao Rd., Sansab, Minburi, Bangkok 10510

Tel. (66 2) 917 3955-8, 543 8890

Fax. (66 2) 917 3959, 543 8891

<http://www.cormix.com>