

GENERAL PURPOSE, SHRINKAGE COMPENSATED CEMENT BASED GROUT

DESCRIPTION

Congrout GP is a non shrink cementitious grout designed for grouting applications where it is necessary to eliminate shrinkage whilst completely filling the gap between the substrate and the base plate. **Congrout GP** was designed for use in local conditions and therefore has extended working times.

USES & ADVANTAGES

Congrout GP is a general-purpose grout designed for use in all non-critical applications.

Advantages includes:-

- Expansion system eliminates shrinkage in plastic state.
- Non Metallic.
- Only requires addition of water.
- Good early and ultimate strength.
- Low permeability.
- Excellent flowability.
- Use for concrete repair work.
- Chloride free.

PROPERTIES

Appearance:	Grey powder
Bulk Density:	Approx. 1.60-1.68 kg/litre
Minimum gap width:	5 mm.
Yield:	Approx. 74-76 x 25 kg bag per m ³ of grout
Water by weight of Grout:	15.5-16.0%
Bond Strength to Concrete:	> 2 N/mm ² at 7 days > 3 N/mm ² at 28 days
Drying Shrinkage:	< 500 micro strain at 28 days
Resistivity:	<12,000 ohm cm at 28 days

** Properties are typical under laboratory conditions and do not constitute a specification. Field trials are recommended.*

SURFACE PREPARATION

Surfaces should be clean sound and free from oil, grease, laitance and loose particles. Metal surfaces should also be clean and free of rust, oil, grease and contaminants.

FORM WORK

The formwork should be watertight. Therefore a joint sealant should be used to close all points where forms meet and also around the bottom and top of formwork.

PRE-SOAKING

The prepared areas should be flooded with water for 3-4 hours prior to the placement of **Congrout GP** Immediately before the grout is placed all free water should be released from the area to be grouted. There should be NO standing water present when the grout is placed.

MIXING

Congrout GP should be mixed using a suitable mixer. For flowable consistency use a hand drill and paddle with a speed of <400 R.P.M. For large works use a high shear vane grout mixer. Drum mixers are not recommended.

The entire contents of the bag should be added to the pre-measured (3.87-4.00 litres) water while mixing.

DO NOT add more than the maximum water content.

APPLICATION

Ensure the substrate is prepared according to the manufactures recommendations. No free water should be present in the area to be grouted. Ensure that there is sufficient air release holes for entrained air to escape. Mortar should be continuously poured, from one side only, until the gap is completely filled. Maintain continuous head of grout when pouring.

STANDARDS

Passes the following relevant standard sections :-

- ASTM 109-80
- ASTM C232-71
- ASTM C827-82
- ASTM C403-85
- JIS A1108
- BS 1881 Part 116 1983 Compressive Strength
- BS 4551 1980 Flexural Strength
- ASTM 469-83

CURING

To prevent premature surface drying and crazing, cure exposed areas of grout with **Corcure 90** or other approved method.

PACKAGING

25 kg. 4 Ply plastic lined bags.

STORAGE CONDITIONS & SHELF LIFE

Store in dry shaded conditions. The shelf life is at least 12 months if kept dry in original packaging. High temperatures and humidity may reduce shelf life.

HEALTH & SAFETY

Congrout GP is alkaline avoid contact with skin & eyes. Gloves, goggles and dust mask should be worn. Skin should be washed with water to remove & splashes in the eyes washed out with copious amounts of clean water and medical attention sought. **Congrout GP** is nonflammable.

GENERAL PURPOSE, SHRINKAGE COMPENSATED CEMENT BASED GROUT

TYPICAL CHARACTERISTICS AT 30⁰C UNDER LABORATORY CONDITIONS

Water Content (%)	Consistency (J rote)	Setting time (hours-minutes)		Bleeding	Average Compressive Strengths (N/mm ²)			
		Initial	Final		1 day	3 days	7 days	28 days
15.5-16.0	8-14 seconds	4.0 - 5.0	4.3 - 5.3	0	35-40	45-50	58-62	68-72

Typical hopper set up for Grouting with Congrout GP

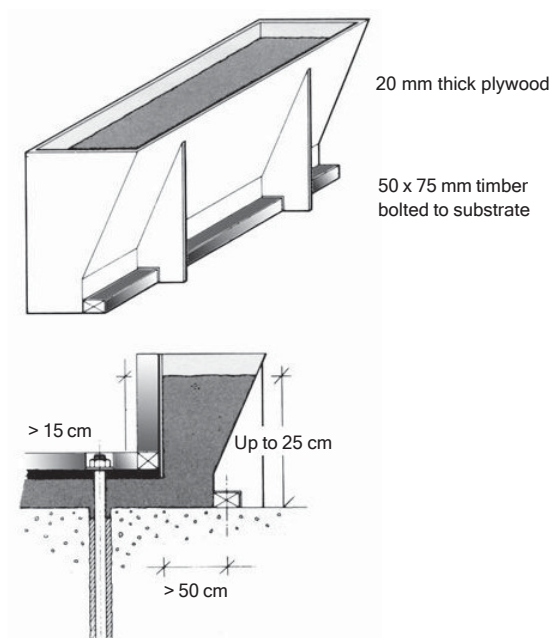

TECHNICAL SERVICE

The Cormix International Technical Service Department is available to assist you in the correct use of our products and its resources are at your disposal entirely without obligation.

QUALITY ASSURANCE

ISO 9001 : 2008 verified by TUV Nord.

CONTACT DETAILS

Cormix International Limited

Regional Office,
89 Romklao Rd., Sansab, Minburi, Bangkok 10510
Tel. (66 2) 917 3955-8, 543 8890
Fax. (66 2) 917 3959, 543 8891
<http://www.cormix.com> E-mail : info@cormix.com

NOTE : Every reasonable precaution is taken in the manufacture of all CORMIX-products to ensure that they comply with CORMIX's high standard of quality. The recommendations and properties of the product are based upon what is believed to be the most reliable information available, and are not intended as recommendations which infringe on other patents. Although all CORMIX-products are subject to rigid quality tests, no specific guarantee can be given, because results depend, not only on quality, but also on other factors beyond our control. We welcome therefore consultation in the event of doubt concerning application, or performance, and point out that oral recommendations, which vary from the instructions contained herein, are not binding without written confirmation by CORMIX. All transactions shall be subject to our terms and conditions of sale-delivery-and-service. This data sheet supersedes the previous one and a reprint may be issued without notice to supersede this edition, as and when deemed necessary. The information given in this leaflet is to the best of our knowledge true and reliable. Field service where provided does not constitute supervisory responsibility. Our guarantee is therefore limited to the quality of materials delivered.