

NON SHRINK HIGH EARLY STRENGTH PRECISION GROUT

DESCRIPTION

A cementitious non shrink precision grout with high early & final strengths specifically for applications where early loading is required. A self leveling, premixed, non metallic grout which produces a dense durable homogeneous mix with no long term shrinkage.

USES & ADVANTAGES

Developed to provide a flowable grout for precision grouting where high early strength is a necessity e.g. bridge bearings, machinery base-plates, column sole plates, anchor & rail bolts etc.

Advantages include:-

- High flow characteristics to fill voids easily.
- No bleeding and controlled expansion.
- Excellent durability. Free calcium oxide compensates shrinkage in both plastic and hardened stages.
- Silica fume improves strengths & long term durability.
- Expansive component shows excellent high heat & seawater resisting characteristics.
- Non rusting, contains no chlorides, non toxic, non corrosive.
- Ready to use & economical.
- Excellent dimensional stability.
- Early strength allows early loading.
- Good resistance to air & waterborne corrosive elements.
- Chloride Free.

PROPERTIES

Appearance: Grey powder

Bulk Density: Approx. 1.60-1.62 kg./litre

Yield: Approx. 74-75 x 25 kg/bags/m³
of grout depends on water content

Slump Cone: ≥90 cm

Bond Strength to Concrete: > 2 N/mm² at 7 days
> 3 N/mm² at 28 days

Drying Shrinkage: < 500 micro strain
23°C C/RH 50% ASTM at 28 days

Resistivity: < 12,000 ohm cm
at 28 days

SURFACE PREPARATION

Surface should be clean, sound and free from oil, grease, laitance and loose particles. Metal surfaces should also be clean & free from rust, oil & grease.

Bolt holes or fixing pockets must be cleaned out with blown clean air.

MIXING

Congrout 4000 should be mixed using a suitable mixer. For flowable consistency use a hand drill and paddle with a speed of < 400 rpm. For large works use a high shear vane grout mixer. Drum mixers may not mix effectively.

Powder should be added to the pregauged water. A free flowing and self leveling grout can be obtained at a mix ratio of 25 kg. powder to 3.375 - 3.750 litres of water.

APPLICATION

Ensure the substrate is correctly prepared, no contamination and saturated with water at least 3 - 4 hours prior to pouring the grout. No free water should be left. Ensure air entrained into the grout is able to escape. Maintain continuous head when base-plate grouting. Mortar flow should not be interrupted. Formwork should not allow grout loss. Base plates must be clean and free from oil, grease or scale. Air venting holes should be provided to allow venting in isolated spots. Place the grout within 10 minutes of mixing.

STANDARDS

Passed the following relevant standard sections :-

ASTM 109-80

ASTM C232-71

ASTM C827-82

ASTM C403-85

ASTM A1108

CURING

To prevent rapid surface drying and crazing, use a suitable curing compound from Cormix's Corcure range. e.g. **Corcure 90**. At temperatures below 20°C early strength gain maybe affected.

IMPORTANT NOTES

- Cure the grout.
- Do not add other materials to the grout.
- Do not re-temper after initial set.
- Bolt holes should be grouted prior to grouting between substrate and base plate.
- Continuous flow should be maintained with a continuous head of grout.
- Large volumes may be pumped. At temperatures above 35°C - 40°C cooling of water with ice will make handling & placement easier. Mixers & tools should be kept shaded.

CONSUMPTION

Depending on water content used approximately 74-75 x 25 kg bags for 1 m³ of mortar.

CLEANING

Clean all tools with water immediately after use.

Congrout[®] 4000



NON SHRINK HIGH EARLY STRENGTH PRECISION GROUT

TYPICAL PERFORMANCE CRITERIA

Water Content (%)	Consistency (J rote) Initial	Bleeding	Wet State Expansion	Average Compressive Strengths (N/mm ²)			
				8 hours	10 hours	24 hours	28 days
13.5	18-22 seconds	0	1-2 %	> 42	> 56	> 70	> 90
14.0	11-15 seconds	0	1-2 %	> 40	> 53	> 67	> 85
14.5	8-12 seconds	0	1-2 %	> 30	> 45	> 60	> 80

Note : These are typical results mixing time, water content and ambient temperature will effect result.

Typical hopper set up for grouting with Congrout 4000

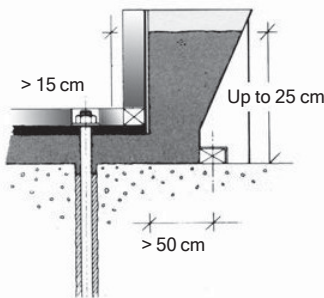
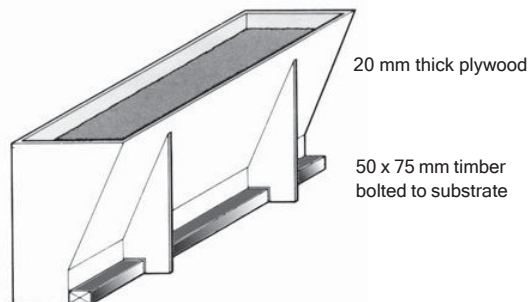

PACKAGING

4 Ply. 25 kg. plastic lined bags.

STORAGE & SHELF LIFE

Store in dry shaded conditions. The shelf life is at least 9 months if kept dry in original packaging. High temperatures and humidity may reduce shelf life.

HEALTH & SAFETY

During use avoid inhalation of dust & contact with skin & eyes. Wear protective clothing. In case of contact with skin, rinse with plenty of clean water, then cleanse with soap and water. In case of contact with eyes, rinse immediately with plenty of clean water and seek medical advice. If swallowed, seek medical attention immediately - **DO NOT** induce vomiting.

TECHNICAL SERVICE

The Cormix International Technical Service Department is available to assist you in the correct use of our products and its resources are at your disposal entirely without obligation.

QUALITY ASSURANCE

ISO 9001 : 2008 verified by TUV Nord.

CONTACT DETAILS

Cormix International Limited

Regional Office,
89 Romklao Rd., Sansab, Minburi, Bangkok 10510
Tel. (66 2) 917 3955-8, 543 8890
Fax. (66 2) 917 3959, 543 8891
<http://www.cormix.com> E-mail : info@cormix.com

NOTE : Every reasonable precaution is taken in the manufacture of all CORMIX-products to ensure that they comply with CORMIX's high standard of quality. The recommendations and properties of the product are based upon what is believed to be the most reliable information available, and are not intended as recommendations which infringe on other patents. Although all CORMIX-products are subject to rigid quality tests, no specific guarantee can be given, because results depend, not only on quality, but also on other factors beyond our control. We welcome therefore consultation in the event of doubt concerning application, or performance, and point out that oral recommendations, which vary from the instructions contained herein, are not binding without written confirmation by CORMIX. All transactions shall be subject to our terms and conditions of sale-delivery-and-service. This data sheet supersedes the previous one and a reprint may be issued without notice to supersede this edition, as and when deemed necessary. The information given in this leaflet is to the best of our knowledge true and reliable. Field service where provided does not constitute supervisory responsibility. Our guarantee is therefore limited to the quality of materials delivered.