

# Contite® Waterstop S



## HYDROPHILIC CONSTRUCTION JOINT WATERSTOP FOR SALINE CONDITIONS

### DESCRIPTION

**Contite Waterstop S** is a hydrophilic waterstop for use in saline water conditions that expands when exposed to water sealing concrete joints. It is used in both horizontal and vertical construction joints in cast insitu concrete and produced using natural sustainable materials which do not negatively impact the environment unlike butyl & chloroprene rubber profiles.

### USES & ADVANTAGES

**Contite Waterstop S** is used as a waterstop in construction joints in below and above grade structures such as water tanks, waste water treatment plants, tunnels, basements, lift shafts, underground stations, subway systems, manholes, culverts, reservoirs, potable water treatment plants, swimming pools, canals etc.

The advantages of the product are as follows :-

- Produced from environmentally friendly sustainable materials.
- Light weight flexible coils easy to install.
- Eliminates seam welding & split forming associated with PVC/rubber waterbars.
- Butt end joining, continuous waterstop.
- Withstands hydrostatic head up to 70 metres.
- Forms a positive seal, sealing cracks & small voids.
- Non toxic.
- Can apply to irregular concrete surfaces. No need to level.
- Compressible and malleable allowing for good contact in precast applications.
- Unaffected by repeated wetting & drying cycles.
- Does not deteriorate.
- Fast installation.
- Permanently active system.
- Ecologically safe & can be used in structures in contact with potable water.
- Self healing.
- Excellent bond.
- Can apply in saline conditions.

### TYPICAL PROPERTIES

<b>Hydrostatic Head Resistance</b>	: > 70 m
<b>S.G.</b>	: 1.5-1.6 ASTM D-71
<b>Wet / Dry Cycling</b>	: No effect
<b>Service Temperatures</b>	: -30°C to 80°C
<b>Elongation</b>	: >100%
<b>Colour</b>	: Black other colours available min. volumes apply
<b>Adhesion to Clean Dry Concrete</b>	: Excellent
<b>Typical Expansion in Saline Conditions</b>	: Approx. 170-300%

### Note :

- Swelling rates 100% indicates original size.
- Expansion is related to the quality of water, temperatures, age of material and storage conditions.

- Expansion rates vary in salt or contaminated water consult the manufacturer before use.
- Expansion rate at 23°C in potable water at 28 days. Specification shown may be changed without notice to improve the product.
- Properties are typical under laboratory conditions and do not constitute a specification. Field trials are recommended.
- Provide at least 75 mm. concrete cover. Increase cover where light weight or low strength concrete is being used .
- Do not use in expansion joints.

### Typical Swell Rates in Salt Water

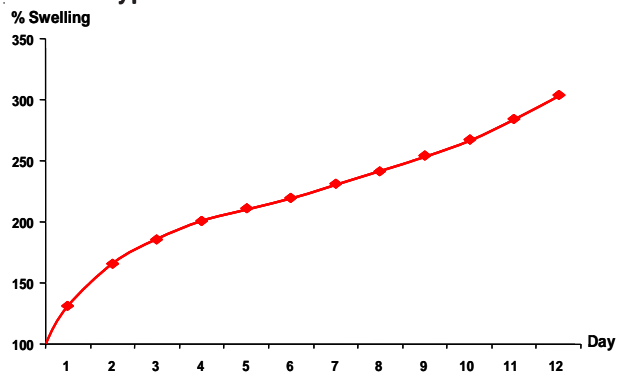

Typical data in laboratory conditions. Data does not constitute a specification.

### INSTALLATION

#### Surface Preparation

The surface should be clean, free of all curing compounds, mould oils, and dry with all dirt, aggregate, dust, debris or standing water removed.

#### General Installation Instructions

Apply by brush **Contite Waterstop S** adhesive along the concrete by the width of **Contite Waterstop S**. Whilst still tacky (within 10-15 minutes) apply the **Contite Waterstop S**. Remove the release paper and press the **Contite Waterstop S** firmly to the surface for several seconds. At the highest coil end on vertical sections pay particular attention. If the adhesive has dried out reapply to the surface. Mechanical fasteners may be used in conjunction with adhesive. Tightly butt end together to form a continuous waterstop. If severe ground water chemicals or salts exist consult with Cormix International Limited.

**Contite Waterstop S** is not self adhering.

### DRAWING DETAILS

#### Footing Joint Vertical Wall Joint

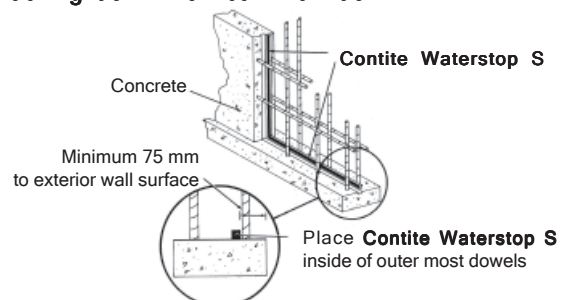

Typical placement of **Contite Waterstop S** at concrete construction joints

# Contite<sup>®</sup> Waterstop S



## HYDROPHILIC CONSTRUCTION JOINT WATERSTOP FOR SALINE CONDITIONS

### INSTALLATION



1. Apply by brush **Contite Waterstop Adhesive** along the concrete by the width of waterstop.



2. Remove the release paper and apply **Contite Waterstop S** while adhesive is tacky about 10-15 minutes, press firmly to the substrate.



3. Mechanical fasteners or nails can also be used in conjunction with adhesive.

### PENETRATIONS

For penetration follow the general installation procedures.

**Single Pipe:** install around outer diameter of the pipe.

**Multiple pipe:** install around each pipe as well as around block out box construction.

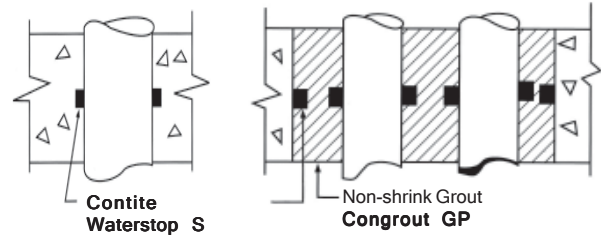

**Sleeved Pipe:** Install around the outer diameter of the sleeve. Install another strip between sleeve's inner diameter & the pipe if there is an excessive gap between inner diameter of the sleeve & the pipe 2 separate waterstops may require installing one on the inner diameter & the other on the pipe. The void should be filled with **Congrount GP** non shrink cementitious grout.

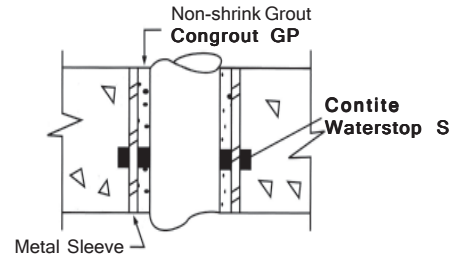

Placement of **Contite Waterstop S** (25 x 20 mm.) at typical construction joints.

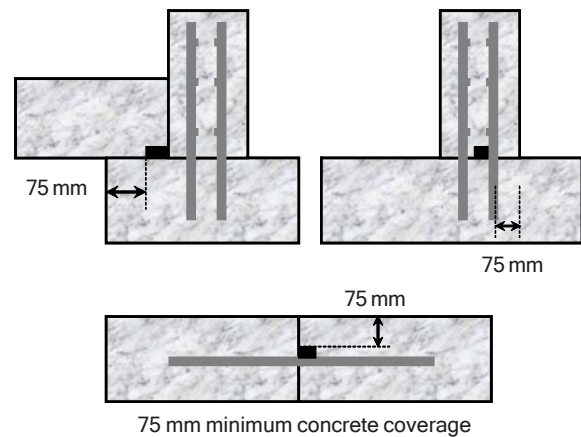

# Contite® Waterstop S



## HYDROPHILIC CONSTRUCTION JOINT WATERSTOP FOR SALINE CONDITIONS

**Pile Caps & Grade Beams:** Install to all construction joints around or adjacent to pile caps & grade beams. Install **Contite Waterstop S** around pile caps and grade beams above waterproofing. Wrap around all I-beams extending out of pile cap & encircle reinforcement out of pile cap.

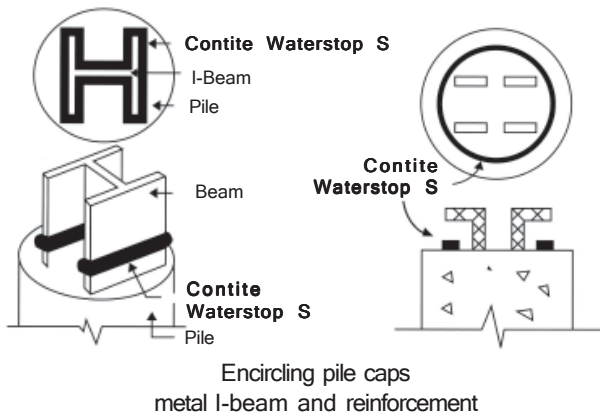

**Irregular Concrete Surfaces:** Press **Contite Waterstop S** against irregular contours filling cavities and cracks do not leave gaps between water bar and surface. It may prove necessary to install in an irregular direction to avoid major depressions or cracks.

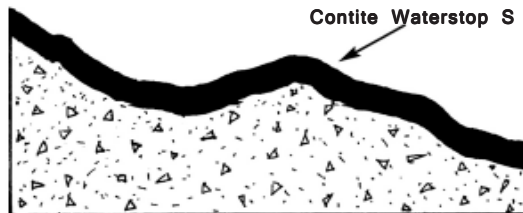

**Joining to PVC Waterstop:** Follow general instructions above. Install **Contite Waterstop S** on the interior side of the PVC water bar place in direct contact and overlap the PVC water bar by at least 7.5 cm. For detailed drawings and for conditions not shown below contact Cormix International Limited.

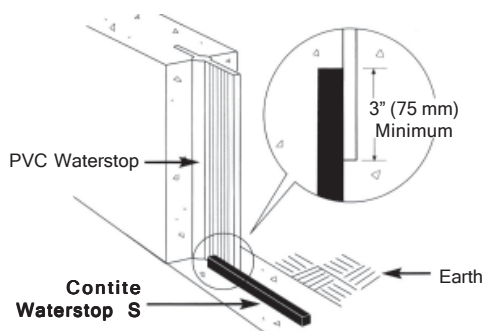

### Contite Waterstop Delay Coating

If rain is anticipated before the pouring of concrete **Contite Waterstop S** may be protected by **Contite Waterstop Delay Coating**. The delay coating is applied to the surface of **Contite Waterstop S** either by brush or spray and will delay swelling for up to several days.



Application by spray



Application by brush

### SPECIFICATION

The waterstop to be used in all construction joints shall be **Contite Waterstop S** or equal approved material. The product shall swell in saline water conditions. The waterstop shall consist of sodium bentonite in natural rubber and expand by at least 170%. It shall be capable of being butt ended, shall not be overlapped nor create a packing effect in the concrete, it shall be pliable so that it follows the contours of the concrete and may be installed to all penetrations. The material will form a positive seal, form a continuous waterstop and withstand hydrostatic pressure up to 70 m.

### PACKAGING & SIZES

#### Approximate size :-

25 x 20 mm x 5.0 LM

6 rolls per carton.

Other sizes available on request.

**Primer / Adhesive** : 5 litre plastic pails

1 litre per 25-35 LM of standard profile 25x20 mm.

**Delay Coating** : 5 litre plastic pails

1 litre per 10-12 LM of standard profile 25x20 mm.

# Contite® Waterstop S



## HYDROPHILIC CONSTRUCTION JOINT WATERSTOP FOR SALINE CONDITIONS

### STORAGE & SHELF LIFE

Store dry in original boxes undercover protected from direct sunlight and rain. The shelflife is at least 12 months.

### HEALTH & SAFETY

There are no known hazards associated with **Contite Waterstop S** during normal use. Refer to product material safety data sheet.

### LIMITATIONS

**Contite Waterstop S** should only be used in applications where ground water is not contaminated, in such cases consult with **Cormix**. **Contite Waterstop S** should be used in areas fully confined in concrete by a minimum of 75 mm cover. To achieve success the installation instructions must be followed. Any hydrated material allow to dry before placement of concrete.

### TECHNICAL SERVICE

The Cormix International Technical Service Department is available to assist you in the correct use of our products and its resources are at your disposal entirely without obligation.

### QUALITY ASSURANCE

ISO 9001 : 2008 verified by TUV Nord.

### CONTACT DETAILS

#### **Cormix International Limited**

Regional Office,

89 Romklao Road, Sansab, Minburi, Bangkok 10510

Tel. (66 2) 917 3955-8, 543 8890

Fax. (66 2) 917 3959, 543 8891

<http://www.cormix.com> E-mail : [info@cormix.com](mailto:info@cormix.com)

**NOTE :** Every reasonable precaution is taken in the manufacture of all CORMIX-products to ensure that they comply with CORMIX's high standard of quality. The recommendations and properties of the product are based upon what is believed to be the most reliable information available, and are not intended as recommendations which infringe on other patents. Although all CORMIX-products are subject to rigid quality tests, no specific guarantee can be given, because results depend, not only on quality, but also on other factors beyond our control. We welcome therefore consultation in the event of doubt concerning application, or performance, and point out that oral recommendations, which vary from the instructions contained herein, are not binding without written confirmation by CORMIX. All transactions shall be subject to our terms and conditions of sale-delivery-and-service. This data sheet supersedes the previous one and a reprint may be issued without notice to supersede this edition, as and when deemed necessary. The information given in this leaflet is to the best of our knowledge true and reliable. Field service where provided does not constitute supervisory responsibility. Our guarantee is therefore limited to the quality of materials delivered.